

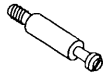









Thank you for purchasing the Performance Bullet Table.
Please follow these instructions for easy assembly.

1  Cam Lock 6 Pcs	2  Klix Cam 6 Pcs	3  Housing Cap 6 Pcs	4  Adjustable Glide 3 Pcs	5  6 Hole L-Bracket 3 Pcs	6  Screw #6 x 5/8" 18 Pcs	7  JCBC M6 x 15mm 4 Pcs	8  M4 x 65 Allen-Key 1 Pc
---	---	--	---	---	---	--	--

A  Top Panel	B  Side Panel	C  Side Center Panel	D  Metal Leg
---	--	---	---

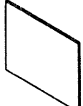
KLIX CAM INSTRUCTIONS

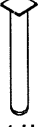
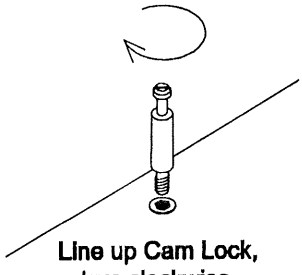
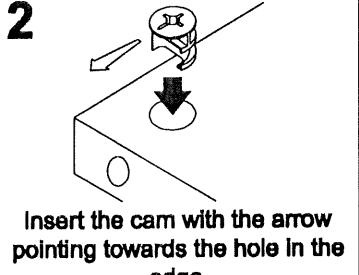
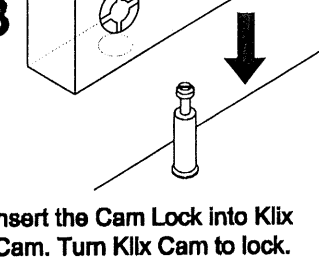
1  Line up Cam Lock, turn clockwise.	2  Insert the cam with the arrow pointing towards the hole in the edge.	3  Insert the Cam Lock into Klix Cam. Turn Klix Cam to lock.
---	---	--

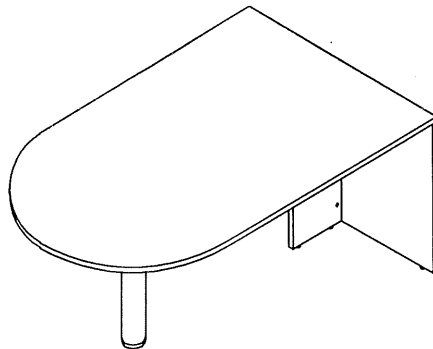

IMPORTANT NOTE :

- Place all wooden parts on a clean and smooth surface such as a rug or carpet to avoid the parts from being scratched.
- Check to be sure that you have all parts and hardware.
- Remove all wrapping materials, including staples & packing straps before you start to assemble.
- Do not tighten all screws/bolts until all completely assembled.
- Keep all hardware parts out of reach of children.

1

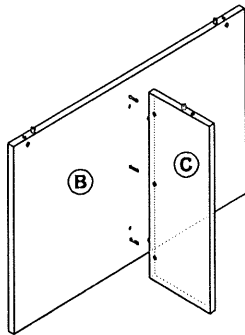

Attach the Side Center Panel (C) to Side Panel (B) by using Cam Lock (1) and Klix Cam (2).

2

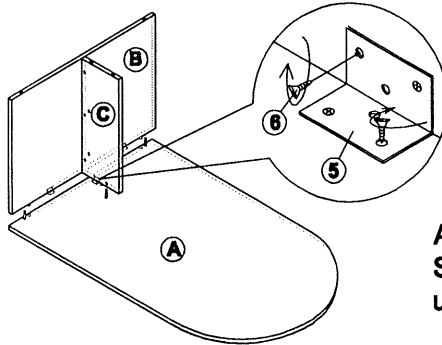

Attach the L-Bracket (5) to Top Panel (A), Side Panel (B) and Side Center Panel (C) as shown. Tighten Screws (6) securely.

Attach the Side Center Panel (C) and Side Panel (B) to Top Panel (A) by using Cam Lock (1) and Klix Cam (2).

3

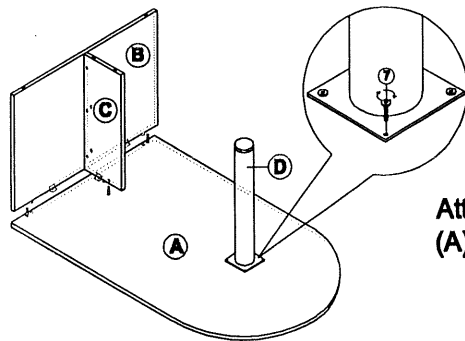

Attach the Metal Leg (D) to Top Panel (A) by using JCBC Screw (7).

4

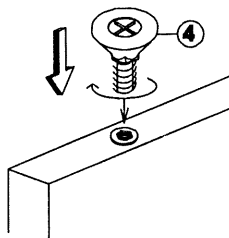

Screw Adjustable Glide (4) into bottom of Side Panel (B) and Side Center Panel (C).

5

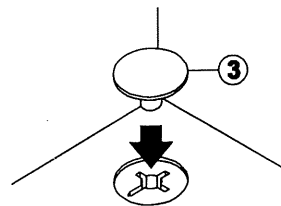

Attach Housing Cap(3) to all Klix Cam(2) by pushing neck through center of cam.